



Iranian Journal of Applied Linguistics (IJAL)

Vol. 26, No. 1, March 2023, 102-124

The relationship between EFL students' anxiety coping strategies and their language learning anxiety as mediated by self-efficacy beliefs

Forough Rekabizadeh

English Department, Shahid Rajaei Teacher Training University, Tehran, Iran

Mavadat Saidi*

English Department, Shahid Rajaei Teacher Training University, Tehran, Iran

Abstract

The study aimed to examine the mediating role of self-efficacy beliefs in the relationship between coping strategies and language learning anxiety using Structural Equation Modeling (SEM). A total of 783 language learners participated in this research and completed Coping with Language Anxiety Scale, Foreign Language Anxiety Scale, and Self-Efficacy Belief Scale. The data were analyzed using SEM to test the hypothesized mediation model. Results indicated that coping strategies were negatively associated with language learning anxiety. Furthermore, self-efficacy beliefs partially mediated the relationship between coping strategies and language learning anxiety. Specifically, higher levels of self-efficacy were found to enhance the negative effect of coping strategies on language learning anxiety. These findings highlight the importance of promoting coping strategies and self-efficacy in language learning contexts to reduce anxiety. The implication of these findings for language learners, educators, and researchers are discussed, along with suggestions for future research in this area.

Keywords: Anxiety Coping Strategies, Language Learning Anxiety, Self-efficacy Beliefs, Structural Equation Modeling

* *Corresponding author:* English Department, Shahid Rajaei Teacher Training University, Tehran, Iran.

Email address: m.saidi@sru.ac.ir

1. Introduction

In recent years, the field of language learning has shown a great interest in exploring the interplay between psychological factors and language acquisition issues (Freire et al., 2020; Yelgeç & Dağyar, 2020). One area that has gained significant attention is language learning anxiety. Anxiety experienced by language learners can interrupt their progress and negatively impact their performance in different language tasks (Jamil et al., 2022; Orgrodzinski, 2022). Researchers have worked on the ways that individuals used to cope with anxiety in language learning contexts (Bernal, 2021; Pabro-Maquidato, 2021; Yousofi & Ashtarian, 2015), and how these coping strategies could influence their overall language learning experience (Durdevic, 2022).

Anxiety coping strategies refer to the cognitive and behavioral efforts employed by individuals to manage or alleviate feelings of anxiety (Lazarus & Folkman, 1984). Previous studies have identified a range of coping strategies adopted by language learners, such as avoidance, seeking social support, positive self-talk, and problem-solving (Kondo & Ying-Ling, 2004; Lazarus & Folkman, 1984). These strategies are considered essential for regulating anxiety and moderating its destructive effects on language learning. However, the relationship between anxiety coping strategies and language learning outcomes is not straightforward, as additional factors may mediate this relationship.

One potential mediator that has garnered attention in this research is self-efficacy beliefs. Self-efficacy refers to an individual's belief in their ability to successfully perform specific tasks or accomplish goals (Bandura, 1993). In the context of language learning, self-efficacy beliefs reflect learners' confidence in their linguistic abilities (Zhao, 2022) and their perceptions of their capacity to overcome challenges and succeed in language tasks (Lianto, 2019). It is hypothesized that self-efficacy beliefs may serve as a mediating mechanism through which anxiety coping strategies influence language learning outcomes.

The purpose of this study was to examine how self-efficacy beliefs could mediate the relationship between anxiety coping strategies and language learning anxiety. Through this investigation, we aimed to uncover the mechanisms that could explain how anxiety coping strategies would affect language learning anxiety, which in turn would impact language learning outcomes.

The findings from this study can contribute to the development of interventions and support systems that improve language learners' coping strategies and alleviate anxiety-related barriers. This knowledge can benefit educators, language instructors, and researchers involved in enhancing language learning experiences.

In the present study, the role of self-efficacy beliefs in EFL students' coping strategies with language learning anxiety was carefully examined using Structural Equation Modeling (SEM). Figure 1 illustrates the structured model, including the direct and indirect pathways. The study hypothesized that:

1. There is a significant relationship between EFL students' self-efficacy and their coping strategies.
2. There is a significant relationship between EFL students' self-efficacy beliefs and their language learning anxiety.
3. The EFL students' self-efficacy functions as a mediator in the relationship between their coping strategies and language learning anxiety.

Figure 1. The structural Model of the Study

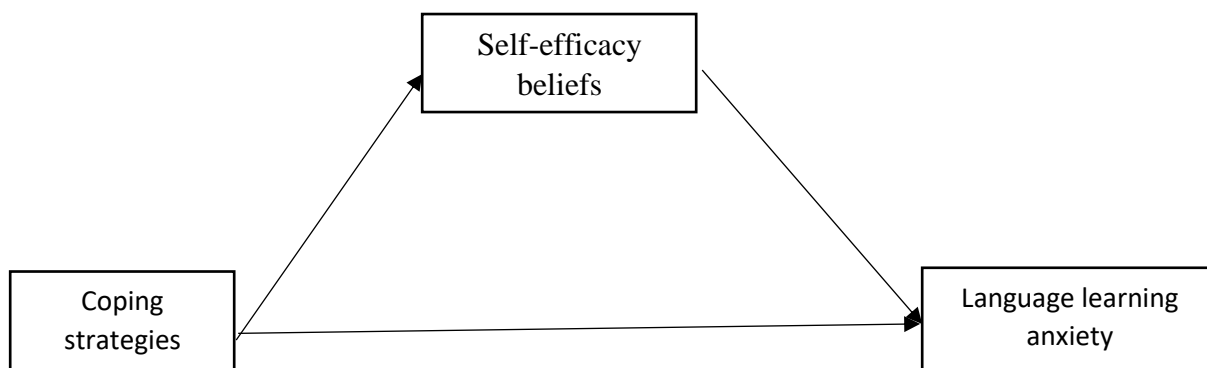

2. Review of the Related Literature

2.1. Language Learning Anxiety (LLA)

Horwitz et al. (1986) considered foreign language anxiety as a distinct combination of self-perceptions, beliefs, feelings, and behaviors related to language learning classroom which can cause

difficulties in language learning by negatively affecting cognitive processes. Language learning anxiety can be facilitative or debilitating. According to Scovel (1987), those anxiety types that give the learners the motivation to fight for reaching a goal are facilitative anxieties, and those that stimulate the learners to take an avoidance approach are debilitating ones. Those who become anxious in certain situations are considered to have state-anxiety which is a social type of anxiety. State-anxiety is represented in a form of an emotion and can be changed across time. So, the emotions and behaviors are influenced by this type of anxiety. Individuals suffering from situation-specific anxiety get anxious only in the presence of certain factors in certain conditions, like testing in a foreign language class. Thus, language learning anxiety is categorized as a situation-specific anxiety (Horwitz et al., 1986).

English language anxiety derives from different sources. It can come from both the internal sources and the external ones. According to Sun (2022), internal causes like gender, personality, and self-confidence are more difficult to solve and in contrast, external causes are influenced by the school environment namely, teacher's attitude, cultural background, and mother tongue. Another cause is lack of coping skills to deal with various types of anxiety in different situations (Ogrodzinski, 2022).

Horwitz et al. (1986) identified three components of language learning anxiety as communication-apprehension, test anxiety, and fear of negative evaluation. Communication apprehension is a type of shyness identified by fear of or anxiety about communicating with people. Such kind of anxiety leads to difficulty in both speaking and listening skills. The students are afraid of speaking in English classes because they may worry too much about making grammatical errors (Anggraini et al., 2022). The second component, test anxiety relates to the fear of bad performing or making mistakes or failing a test. Several students believe nothing should be articulated in the foreign language until it can be said fluently and accurately but the students are expected to speak and communicate before being fluent and even high-level students may forget words or make mistakes. This is common among test-anxious students who believe that anything less than a perfect test performance is a failure (Horwitz et al., 1986). And the third component, fear of negative evaluation, is the perceptions of others' evaluations. Such fear makes the students feel that others would evaluate them negatively. They worry about others' opinions (MacIntyre & Gardner, 1994). This type of anxiety not only affects the performance of students in the classroom but also causes inadequate

performance outside the educational settings (Horwits et al., 1986). Past negative experiences such as failing marks or not having a good presentation also lead to anxiety in the same situations (e.g., giving another lecture in the future) (Anggraini et al., 2022). So, as believed by Sun (2022), fear is a sign of anxiety.

Rahmat (2022) developed the cycle of fear of foreign language learning and reported that in the language learning procedure, students mostly felt communication apprehension when they failed to understand and were asked to have impromptu presentations. Since the nature of communication is creative, the foreign language class is subconsciously anxiety-provoking. Test anxiety also occurred mostly when they were worried about the consequences of failing and speaking in front of peers. Moreover, thinking that others were better and being asked to answer a question when they were not prepared were the most commonly reported reasons underlying fear of negative evaluation. At last, she demonstrated that the expectations could affect the communication apprehension. This apprehension intensified the anxiety during testing. Then, this anxiety caused more fear-related behaviors such as fear of negative evaluation by peers and teachers. All these sets of anxiety resulted in fearing the foreign language class.

2.2. Anxiety Coping strategies

Coping is the most advanced process of adaptation, and is defined as "constantly changing cognitive and behavioral efforts to manage specific external and/or internal demands that are appraised as taxing or exceeding the resources of the person" (Lazarus & Folkman, 1984, p.141). It may also use interchangeably with defense and adaption (Kao & Craigie, 2013).

According to Lazarus (1993), there are two types of coping efforts, 1) emotion-focused, in the sense that the disturbing relationship between the person and the environment is modified by acting on the environment or on oneself; emotions can change from the beginning to the end of this process-oriented effort (Hudson, 2016), and 2) problem-focused which refers to the way to act changes the stressful relationship with the environment or the relational significance of what happens to reduce stress, even if the actual state of the relationship has not changed.

Ultimately, Lazarus (1993) identified two psychological sources to deal with threatening personal meanings. Since they can be caused by environmental pressure or can be internal, these two sources include 1) social and personality traits such as supportive family, friends, financial support,

ego strength, intelligence, and ability, and 2) stress and emotions. Emotions are the best source to show how people get along in different adaptational encounters. Stress is considered as a subset of emotions. The anger, fear, guilt, shame, sadness, envy, jealousy, and disgust that arise from conflicts are referred to as stressful emotions. We learn different things from each emotion about a person's interaction with the environment, the environment itself, and the type of person we are dealing with (Lazarus, 1993).

The transactional model of stress and coping presented by Lazarus and Folkman (1984) implied that coping strategies are influenced by the emotional functions or feelings we experience in a particular situation. For instance, those who have higher self-efficacy can better cope with anxiety (Freire et al., 2020). According to Lazarus and Folkman, these emotional functions include self-control in which individuals try to manage and control their stress, confrontation in which individuals try to bring the stressful situation back to their favor, social support in which individuals look for some social connections to support and help them in the problem, emotional distancing in which individuals are unconcerned and do not let the stress control them, escape and avoidance in which individuals deny the stress, radical acceptance in which individuals turn to unconditional self-acceptance, positive reappraisal in which individuals try to find a path to grow through the problem, and strategic problem-solving in which individuals try to use specific solution-focused strategies to cope with the threat. So, this model focuses on ways to reduce stress and negative emotions resulting from negative individual or environmental transactions.

While students experience any sorts of foreign language learning anxiety, they increase their use of coping strategies to reduce and control it (Kao & Craigie, 2013). Kondo and Ying-Ling (2004) identified five strategies to cope with anxiety including preparation, relaxation, positive thinking, peer seeking, and resignation. In the preparation strategy, the students prepare themselves before the class by studying the lesson, taking notes, or checking the dictionary and in the relaxation strategy, they try to be calm by body movements or breathing deeply. Moreover, in the positive thinking strategy, they may imagine themselves giving a good presentation, having a good performance in an exam or may avoid overthinking about their mistakes and in peer seeking strategy, they want to find peers who share the same problems in learning and they think they can use each other's experiences to overcome anxiety. In addition, in resignation strategy, they just give up or may sleep in the class.

Previous research investigated the relationship between anxiety and coping strategies, the most common strategies used in dealing with anxiety and the factors influencing the choice of each strategy. According to Kao and Craigie (2013), positive thinking was the strongest predictor of anxiety and it was also the most used coping strategy among students. Bernal (2021) indicated that anxious students mostly used preparation, positive thinking, peer seeking, and relaxation respectively. Surprisingly, using more coping strategies has also been associated with language learning anxiety (Santri et al., 2022; Zargar & Nimehchisalem, 2023). This may imply that higher levels of anxiety may result in more use of the defense mechanisms.

2.3. Self-Efficacy Beliefs

Bandura (1993) defined self-efficacy as "people's beliefs about their capabilities to exercise control over their own level or functioning and over events that affect their lives" (p. 118). Self-efficacy shows the learners' perceptions of what they can do and affects their interests, goals, motivation, and efforts (Moralı & Boran, 2021). Self-efficacy can be also described as a kind of self-confidence in language learning (Zhao, 2022). The construct of self-efficacy refers to acquiring a defined amount of knowledge that helps students feel more confident, more successful, and more motivated (Graham, 2022). The higher the self-efficacy is, the higher their self-confidence will be about their ability to achieve success. In difficult situations, people with lower self-efficacy will easily decrease their efforts or most likely give up. In contrast, people with higher self-efficacy will try harder to master the challenges (Freire et al., 2020; Lianto, 2019).

Bandura (1997) identified four factors that can influence self-efficacy. He categorized these factors as (a) mastery experience, or enactive self-mastery, (b) vicarious experience, or role-modeling, (c) social or verbal persuasion, and (d) arousal or physiological and emotional states. The first resource, mastery experience, which is the most influential factor is related to the successful experiences of individuals during their whole life. The lack of mastery experience causes low self-efficacy beliefs (Sun & Wang, 2020). Likewise, Shirazizadeh et al. (2023) implied that the more experienced students had higher self-efficacy in writing. The second one, vicarious experience, is caused by observing others as models in various situations. Although the skills and abilities of individuals are different, observing convinces the observer to reach the same outcome. As a result, observing failure experiences can have negative effects on self-efficacy and observers' behaviors.

The third one, social and verbal persuasion, is related to the fact that successful persuasion can boost individuals' abilities and how negative persuasion can reduce self-beliefs. The last factor, psychological and affective states like anxiety, can affect efficacy perceptions and improve proficiency. The development of self-efficacy depends on how much individuals can attribute their achievements in a task to her/his efforts, how difficult the task is perceived and how much help is needed for it (Graham, 2022).

Underlying the concept of self-efficacy, social cognitive theory explains that individuals do not respond simply to environmental influences, but rather first seek or interpret related information. This theory is against behaviorism and psychoanalysis psychology which put too much emphasis on the environmental factors as determiners of individuals' behavior. Bandura (1997) proposed a humanistic and existentialist view that emphasizes human roles in conscious judgments and the direction of actions. Individuals are the main contributors that determine what they achieve according to their life choices (Bandura, 1977). Individuals' behavior and motivation are the results of the interaction between a series of factors which are categorized as behavioral, personal, and environmental factors (Lianto, 2019).

Graham (2022) believed that self-efficacy has a direct effect because individuals with high self-efficacy choose more challenging tasks, insist on them for a longer period of time, and consider the results to be related to their controllable methods, and as a result, they achieve more (Bandura, 1994). Consequently, individuals who have high self-efficacy beliefs are more proficient in cognitive, motivational, affective, and selection processes in learning; for example, they can set objectives for their own, plan to reach them, manage their negative feelings which prevent learning such as stress, etc., and make right choices for the learning environment (Bandura, 1997).

According to Piniel and Csizer (2013), higher levels of self-efficacy associated with higher levels of facilitative anxiety and lower levels of debilitating anxiety. Chalavi et al. (2022) recommended teachers to encourage their learners regularly in order to improve their self-efficacy and reduce their learning anxiety since based on previous studies, improving self-efficacy beliefs can reduce the learning anxiety (Ardasheva et al., 2018; Hadriana, 2020). Self-efficacy has also been linked to different types of coping strategies. It had positive correlation with problem-focused coping strategies (Freire et al, 2019; Wang et al, 2023) and negative correlation with emotion-focused one (Chang & Edwards, 2015; Hosseini Dowlatabadi et al., 2014). Moreover, on the report

of Freire et al. (2020) self-efficacious learners were able to use more coping strategies encountering an anxiety-provoking situation. Since much research has been conducted on the relationship between self-efficacy and anxiety concerning different skills (Ardasheva et al., 2018; Özer & Akçayoğlu, 2021; Yelgeç & Dağyar, 2020) and between self-efficacy and coping strategies (Chang & Edwards, 2015; Freire et al., 2020; Hosseini Dowlatabadi et al., 2014; Wang et al., 2023), self-efficacy is supposed to possess a mediating role in the relationship between coping strategies and language learning anxiety. In other words, improving self-efficacy seems to play a facilitative role in reducing students' anxiety by making use of adequate coping strategies.

3. Method

3.1. Participants

The sample consisted of 784 Iranian high school students studying at four state high schools. All the students were female. The data were collected in the Spring of 2023. The sample was selected using convenience sampling and participation was entirely voluntary, with complete confidentiality and anonymity guaranteed. They were informed about the content of the scales and the purpose of the research before going through the questionnaires. Consent was obtained by virtue of survey completion. Relevant demographic information is shown in Table 1.

Table 1. Demographic Information of the Participants (N=784)

Variable	Demographics	Frequency	Percent
Field of study	Humanities	400	51
	Experimental sciences	362	46.2
	Mathematics	22	2.8
Grade	10	275	35.1
	11	305	38.9
	12	204	26

3.2. Instruments

The researchers employed three instruments to collect data; three separate questionnaires including the Coping with Language Anxiety scale, the Foreign Language Anxiety Scale (FLAS), and the Self-Efficacy Belief Scale (SEBS) were distributed.

3.2.1. *The Coping with Language Anxiety Scale (CLAS)*

The modified version of the Foreign Language Anxiety Coping Scale (Marwan, 2007) developed by Kondo and Yang (2004) was used to assess the students' coping strategies. The CLAS included fifteen items with five-point Likert scale ranging from Strongly Disagree to Strongly Agree with values 1-5 assigned to the descriptors, respectively. Besides, the questionnaire contained five negative statements, numbered 5, 6, 9, 10, and 15. The scale used a combination of empirical and theoretical approaches and focused on the study of coping strategies organized by five solutions including preparation (items 1, 6, and 12), relaxation (items 2, 7, and 13), positive thinking (items 3 and 8), peer seeking (items 4, 9, 11, and 14), and resignation (items 5, 10, and 15). The psychometric properties like high reliability, appropriateness to research questions, and being able to signify the coping strategies that interact with the anxiety variable were the reasons of choosing this scale. Marwan (2007) reported a high internal reliability for this scale with Cronbach's alpha value of 0.90. In this study the reliability of the instrument was 0.81.

3.2.2. *The Foreign Language Anxiety Scale (FLAS)*

This was a modified version of the Foreign Language Class Anxiety Scale (FLCAS) (Marwan, 2007) developed by Horwitz et al. (1986) dealing with learners' language anxiety in EFL classrooms. This shortened version was an adaptation of the original questionnaire with 33 items, but it followed the same purpose as other shortened and adapted versions in measuring the level of anxiety (Taghinezhad et al., 2016). This scale comprised 21 items in 5-point Likert scale ranging from Strongly Disagree (1) to Strongly Agree (5). Thus, the possible score range of the questionnaire was between 21 and 105, with the theoretical mean of 63. The FLAS included five components of language anxiety: lack of confidence (items 1, 3, 8, 11, 13, and 14), lack of preparation (items 6, 10, and 18), fear of failing the class (items 7, 15, and 21), fear of making mistakes (items 2, 5, 9, 12, 17, and 20), and difficulty in understanding teachers' instructions (items 4, 16, and 19). Additionally, the questionnaire contained seven negative statements, numbered 2, 5, 9, 11, 15, and 19. Marwan (2007) has reported a high internal reliability for this scale with Cronbach's alpha value of 0.87. The reliability coefficient of the FLAS in this study was .90. The reliability coefficients of the five dimensions of FLAS was also measured: lack of confidence ($r = .83$), lack of preparation ($r = .72$), fear of failing the class ($r = .63$), fear of making mistakes ($r = .62$), difficulty in understanding teachers' instructions ($r = .63$).

3.2.3. *The Self-Efficacy Beliefs Scale (SEBS)*

The Self-Efficacy Beliefs Scale (SEBS) was an adapted questionnaire developed by Tuan et al. (2005) based on the students' self-efficacy belief. This scale included 10 items with 5-point Likert scale ranging from Strongly Disagree to Strongly Agree with values 1-5 assigned to the descriptors respectively. Thus, the possible score range of the questionnaire was between 10 and 50, with the theoretical mean of 30. Further, the questionnaire contained five negative statements, numbered 2, 4, 5, 6 and 7. Tuan et al. (2005) reported the reliability of this scale with a Cronbach's alpha value of 0.7. The reliability coefficient of the SEBS in this study was .83.

3.3. *Procedure*

A total of 800 Iranian high school students studying at four state high schools participated in the current study. After reviewing the data, 16 participants were excluded due to incomplete answers. Therefore, a total of 784 (98%) valid questionnaires were collected. Initially, the questionnaires were translated into Persian to accommodate the proficiency level of all students. Prior to data collection, three experienced university instructors of TEFL reviewed the questionnaires. Necessary adjustments were made based on their feedback, and the modified versions were further scrutinized to ensure question validity. Following this, the research objectives and questionnaire confidentiality were fully explained to the participants, who were provided with the research questionnaires. The printed questionnaires, utilizing the pencil and paper technique, were completed during regular class hours in a single session lasting approximately 30 minutes. Throughout the process, the researcher was present in the classroom, offering helpful explanations whenever needed

3.4. *Data Analysis*

In this study, Structural Equation Modeling (SEM) was employed to assess both the measurement model and the full structured model, which resembled the hypothesized model. Initially, Confirmatory Factor Analysis (CFA) was conducted to evaluate the model fit adequacy. As Avkiran & Ringle (2018) maintained, standardized loadings below 0.4 were deemed unacceptable and removed from further analysis. Subsequently, the Structural Equational Model (SEM) was

implemented, and fit indices were assessed using Amos 24.0.0. The result section reported various fit indices, including the Chi-square Degree of Freedom ratio (χ^2/df), Comparative Fit Index (CFI), Tucker-Lewis Index (TLI), Root-Mean-Square Error of Approximation (RMSEA), and Standardized Root-Mean-Square Residual (SRMR). According to Schumacker and Lomax (2010), a CFI greater than 0.90 indicates an acceptable model fit, while a χ^2/df ratio lower than 5 is indicative of a satisfactory model fit (Wheaton et al., 1977). Additionally, a TLI above 0.90 is considered acceptable (Bentler & Bonett, 1980). For RMSEA and SRMR, values below 0.06 (Hu & Bentler, 1999) and 0.05 (Byrne, 1998), respectively, suggest a good model fit. Mediation analysis was performed to examine the mediating effect of Self-Efficacy Beliefs. Subsequently, a bootstrapping method was employed, involving 2,000 re-samplings and utilizing a 95% bias-corrected percentile interval and percentile confidence interval.

4. Results

4.1. The Measurement Model: The Self-Efficacy Beliefs Scale (SEBS)

The CFA was performed to assess the validity and structure of the model. The results of the first-order CFA indicated a good fit of the model to the data ($\chi^2 = 63.44$, $df = 23$, $\chi^2/df = 2.758$, $p < .000$, SRMR = .0269, RMSEA = .047 [90% CI .034–.062], and CFI = .982). Furthermore, the internal consistency of the scale in the current study was found to be .83.

4.2. The Measurement Model: The Coping with Language Anxiety Scale (CLAS)

The initial Coping with Language Anxiety Scale (CLAS) consisted of 15 items. However, items 9, 11, and 15 were removed from the scale due to the low factor loading. The modified version of the scale, which comprised 12 items, demonstrated a satisfactory fit to the model ($\chi^2 = 108.48$, $df = 48$, $\chi^2/df = 2.260$, $p < .000$, SRMR = .0391, RMSEA = .040 [90% CI .030–.050], and CFI = 0.941). Furthermore, the internal consistency of this scale in the current study was .70.

4.3. The Measurement Model: The Foreign Language Anxiety Scale (FLAS)

The Foreign Language Anxiety Scale (FLAS) consist of five factors including Lack of Confidence, Lack of Preparation, Fear of Failing the Class, Fear of Making Mistakes, and Difficulty in Understanding Teacher's Instructions. Initially, the FLAS model consisted of 21 items. However, after removing items 5 and 9 due to their low factor loading, the revised 19-item model of FLAS exhibited an acceptable model fit ($\chi^2= 400.84$, $df=138$, $\chi^2/df = 2.905$, $p < .000$, $SRMR = .0397$, $RMSEA = .049$ [90% CI .044–.055], and $CFI = 0.947$). Moreover, the internal consistency of this scale in the current study was found to be .90 (See Table 2).

Table 2. The fit indices of Measurement models

Variables	χ^2	Df	χ^2/df	<i>P</i>	TLI	CFI	SRMR	RMSEA
SEB	63.44	23	2.758	.000	.965	.982	.026	.047
Coping strategies	108.48	48	2.260	.000	.919	.941	.039	.041
LLA	400.84	138	2.905	.000	.939	.947	.039	.049

4.4. Descriptive Statistics and Correlational Analysis

Prior to the analysis, as stated by Hair et al. (2013) the missing items were replaced by the mean for the papers with less than 5% missing values, then the normality of the data was checked by evaluating the skewness and skewness coefficients. The results confirmed that the data exhibited normal distribution, as suggested by Hair et al. (2010) and Bryne (2010), where skewness ranging from -2 to +2 and kurtosis ranging from -7 to +7 indicate a normal distribution.

Table 3 presents the descriptive statistics of the variables in the study. The analysis of the language learning anxiety revealed that most students experienced a moderate level of anxiety in foreign language classes ($M=2.98$, $SD=0.85$). On the other hand, the students reported a relatively high level of self-efficacy beliefs ($M=3.67$, $SD=0.77$). Additionally, the students exhibited a relatively high degree of coping strategies ($M=3.70$, $SD=0.56$), indicating their utilization of various coping mechanisms in stressful situations.

SEB was strongly and positively correlated with coping strategies ($r =.63$, $P < .01$). In other words, those students who are more self-efficacious tend to use more coping strategies during the anxiety-provoking situations in a foreign language class. However, higher levels of SEB were associated with the lower levels of LLA since there is negative association between these two

constructs ($r = -.58, p < .01$). Although there was an inverse relationship between SEB and LLA, students who suffer from higher levels of anxiety, generally use fewer coping strategies as there was a significant negative correlation between LLA and anxiety coping strategies ($r = -.33, p < .01$). In fact, it can be said that students with high anxiety are more likely to be unsuccessful in dealing with it.

Table 3. Means, standard deviations, and bivariate correlations between the study variables.

Variables	SEB	Coping strategies	LLA	M	SD	A	skewness	Kurtosis
SEB	1	.63**	-.58**	3.67	.77	.90	-.32	-.57
Coping strategies		1	-.33**	3.70	.56	.69	-.32	-.31
LLA			1	2.98	.85	.90	-.11	-.71

Note: ** $p < .01$; SEB: Self-Efficacy Beliefs; LC: Lack of Confidence; LLA: Language Learning Anxiety.

4.5. The Structural Model and Mediation Analysis

The structural model was assessed using the maximum likelihood estimation (MLE). Table 4 demonstrates the fit indices of the hypothesized model. The results displayed in Table 4 indicate that all the model fit statistics fell within the acceptable ranges.

Table 4. Evaluation of the fit indices for the hypothesized model

Index	Model	Perfect fit	Good or acceptable fit	Decision
χ^2/df	4.63	$\chi^2/df \leq 3$	$\chi^2/df \leq 5$	Good fit
RMSEA	.068	$RMSEA \leq 0.05$	$RMSEA \leq 0.08$	Good fit
SRMR	.042	$SRMR \leq 0.05$	$SRMR \leq 0.08$	Perfect fit
CFI	.95	$NFI \geq 0.95$	$NFI \geq 0.90$	Perfect fit
TLI	.92	$TLI \geq 0.95$	$TLI \geq 0.90$	Good fit
GFI	.95	$GFI \geq 0.95$	$GFI \geq 0.90$	Perfect fit
AGFI	.93	$AGFI \geq 0.90$	$AGFI \geq 0.85$	Perfect fit

Specifically, the chi-square degree of freedom ratio (χ^2/df) was 4.63, the root-mean-square error of approximation (RMSEA) was .068, the standardized root-mean-square residuals (SRMR)

were .042, the comparative fit index (CFI) was .95, the Tucker-Lewis Index (TLI) was .92, the goodness-of-fit index (GFI) was .96, and the adjusted goodness-of-fit index (AGFI) was .93.

The results displayed that coping strategies have a significant positive direct effect on SEB ($\beta = .69, t = 16.31, p < .001$). Also, SEB was found to have a significant positive direct effect on LLA ($\beta = .27, t = 5.75, p < .001$). Together, these findings supported Hypotheses 1 and 2 of the study. The direct path from SEB to LLA was significant as well ($\beta = -.86, t = -13.51, p < .001$).

The results of the mediation analysis can be found in Table 5. The results revealed that coping strategies had a significant direct and indirect effect on LLA via SEB. Taking into account the incorporation of the mediator variable in the model, the direct impact of coping strategies on anxiety remains significant, indicating that self-efficacy beliefs play a partial mediating role in this relationship. The findings of the structural equation model examination are depicted in

Table 5. Direct, indirect, and total effects for the mediation using a Bootstrap Analysis with 95% Confidence Interval

	Direct effect	Indirect effect	Confidence Interval (CI)		Total effect	Confidence Interval (CI)	
Coping strategies → SEB → LLA	.27***	-.60***	Low	High	-.33***	Low	High
			-.70	-.51		-.39	-.26

Note: *** $p < .001$.

Figure 2. The structural equation modeling (SEM) of the interrelationship between the variables

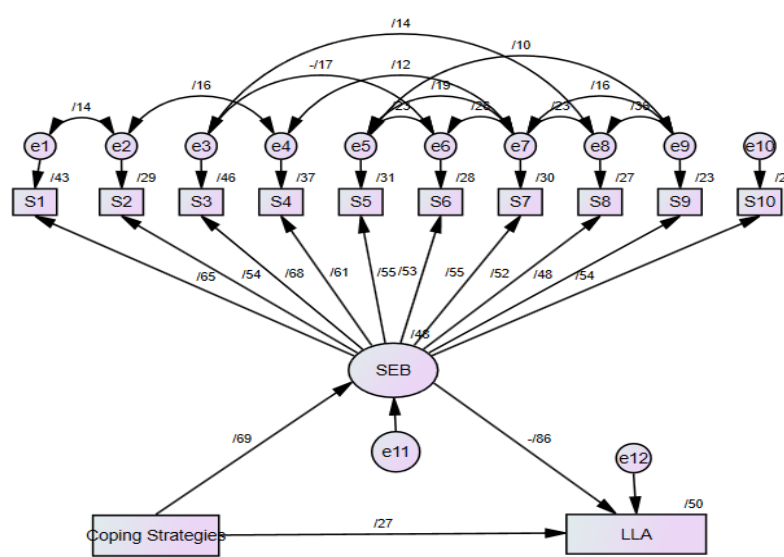

5. Discussion and Conclusion

The findings of the current study shed light on the mediating role of self-efficacy beliefs in the relationship between anxiety coping strategies and language learning anxiety. The results revealed a significant mediating effect of self-efficacy beliefs on the relationship between anxiety coping strategies and language learning anxiety. Specifically, higher levels of self-efficacy beliefs were found to partially mediate the relationship between anxiety coping strategies and reduced language learning anxiety.

Consistent with the existing literature (Ardasheva et al., 2018; Freire et al., 2020; Hadriana, 2020; Pabro-Maquidato, 2021; Yousofi & Ashtarian, 2015), this suggests that individuals who possess stronger self-efficacy beliefs may be more likely to employ adaptive coping strategies, which in turn, leads to lower levels of anxiety in language learning contexts.

The implications of this mediating effect are substantial for language learners, educators, and researchers. Firstly, the findings highlighted the importance of promoting self-efficacy beliefs among language learners. By enhancing learners' confidence in their language learning abilities, educators can potentially help learners develop a more positive mindset towards language learning and cope better with anxiety-provoking situations (Chalavi et al., 2022; Ogrodzinski, 2022). This may lead to improved language learning outcomes and increased motivation (Shen, 2021; Zafarani et al., 2022).

Furthermore, our study emphasizes the significance of coping strategies in managing language learning anxiety. Coping strategies were found to be associated with lower levels of anxiety which is in line with previous studies (Kao & Craigie, 2013; Bernal, 2021) Educators can incorporate these strategies into language learning curricula or provide guidance on their use, equipping learners with effective tools to manage anxiety and enhance their language learning experience.

The mechanisms underlying the mediating effect of self-efficacy beliefs on the relationship between anxiety coping strategies and language learning anxiety can be attributed to several factors. Firstly, individuals with higher self-efficacy beliefs may perceive anxiety-provoking situations as challenges rather than threats (Graham, 2022). Consequently, they may be more inclined to employ adaptive coping strategies to overcome these challenges, leading to reduced anxiety levels. Secondly, self-efficacy beliefs can influence individuals' motivation and persistence in language learning (Bandura, 1997). Learners with stronger self-efficacy beliefs may be more motivated to engage in

language learning tasks, persevere through difficulties, and actively seek out effective coping strategies (Lianto, 2019). This motivation and perseverance can contribute to lower levels of anxiety and a more positive language learning experience.

It is important to acknowledge some limitations of our study. Firstly, the data were collected through self-report measures, which are subject to response biases and social desirability effects. Secondly, our study focused on a specific population or context, and generalizability to other language learning populations should be considered with caution. Thirdly, gender was not considered in this study. Future studies could explore the specific coping strategies that are most effective in reducing language learning anxiety and examine how self-efficacy beliefs interact with other factors, such as language proficiency, cultural background, and learning environment. Additionally, longitudinal studies could investigate the long-term effects of self-efficacy beliefs and coping strategies on language learning anxiety, providing a more comprehensive understanding of this complex relationship.

In conclusion, our study provides valuable insights into the mediating role of self-efficacy beliefs on the relationship between anxiety coping strategies and language learning anxiety. The findings highlight the importance of promoting self-efficacy beliefs and coping strategies in language learning contexts. By promoting self-efficacy, encouraging coping strategies, and considering individual differences, we can create a supportive language learning environment that helps learners effectively manage anxiety and optimize their language learning outcomes.

Declarations

- Ethics approval and consent to participate

The participants voluntarily participated in the study and were assured of the anonymity of the data.

- Availability of data and materials

Data are available upon the request from the corresponding author.

- Competing interests

There are no competing interests.

- Funding

No funding was received.

References

- Anggraini, D., Nugraha, S. I., & Wahyuna, Y. T. (2022). Students' coping strategies with speaking anxiety in online learning setting. *INTERACTION: Jurnal Pendidikan Bahasa*, 9(2), 380-392. <https://doi.org/10.36232/jurnalpendidikanbahasa.v9i2.2962>
- Ardasheva, Y., Carbonneau, K. J., Roo, A. K., & Wang, Z. (2018). Relationships among prior learning, anxiety, self-efficacy, and science vocabulary learning of middle school students with varied English language proficiency. *Learning and Individual Differences*, 61, 21-30. <https://doi.org/10.1016/j.lindif.2017.11.008>
- Avkiran, N. K., & Ringle, C. M. (2018). Partial Least Squares Structural Equation Modeling. *Springer*. <https://doi.org/10.1007/978-3-319-71691-6>
- Bandura, A. (1977). Self-efficacy: Toward a unifying theory of behavioral change. *Psychological review*, 84(2), 191-215. <https://doi.org/10.1037/0033-295x.84.2.191>
- Bandura, A. (1993). Perceived self-efficacy in cognitive development and functioning. *Educational psychologist*, 28(2), 117-148. https://doi.org/10.1207/s15326985ep2802_3
- Bandura, A. (1994). Self-efficacy. *Encyclopedia of Human Behavior*, 4, 71-81.
- Bentler, P. M., & Bonett, D. G. (1980). Significance tests and goodness of fit in the analysis of covariance structures. *Psychological Bulletin*, 88, 588-606. <https://doi.org/10.1037/0033-2909.88.3.588>
- Bernal, A. II. (2021). The mediating effect of classroom learning environment on the relationship between Filipino language anxiety and coping strategies. *SSRN Electronic Journal*. <https://doi.org/10.2139/ssrn.3941206>
- Byrne, B. M. (2010). Structural equation modeling with AMOS: Basic concepts, applications, and programming. New York: Routledge.

- Byrne, B.M. (1998), *Structural Equation Modeling with LISREL, PRELIS and SIMPLIS: Basic Concepts, Applications and Programming*. Mahwah, New Jersey: Lawrence Erlbaum Associates.
- Chang, Y., & Edwards, J. K. (2015). Examining the relationships among self-efficacy, coping, and job satisfaction using social career cognitive theory: An SEM analysis. *Journal of career assessment*, 23(1), 35-47. <https://doi.org/10.1177/1069072714523083>
- Durdevic, M. (2022) Foreign language classroom anxiety and how the neuroscience of connection and emotion regulation can help us to optimize students' L2 learning experience. *unpublished MA thesis*. Alpen-Adria-University, Klagenfurt, Austria.
- Freire, C., Ferradás, M. D. M., Núñez, J. C., Valle, A., & Vallejo, G. (2019). Eudaimonic well-being and coping with stress in university students: The mediating/moderating role of self-efficacy. *International journal of environmental research and public health*, 16(1), 48-63. <https://doi.org/10.3390/ijerph16010048>
- Freire, C., Ferradás, M. D. M., Regueiro, B., Rodríguez, S., Valle, A., & Núñez, J. C. (2020). Coping strategies and self-efficacy in university students: A person-centered approach. *Frontiers in psychology*, 11: 841. <https://doi.org/10.3389/fpsyg.2020.00841>
- Graham, S. (2022) Self-efficacy and language learning– what it is and what it isn't. *The Language Learning Journal*, 50(2), 186-207. DOI: 10.1080/09571736.2022.2045679
- Hadriana, H. (2020). Insignificant relationship between speaking self-efficacy and language learning anxiety of English department students at the university of Riau, Indonesia. *Journal of Social Science Research*, 15, 34–46. <https://doi.org/10.24297/jssr.v15i.8643>
- Hair Jr., J. F., Hult, G. T. M., Ringle, C., & Sarstedt, M. (2013). A primer on partial least squares structural equation modeling (PLS-SEM) (pp. 1–307). SAGE Publications, Incorporated.
- Hair, J., Black, W. C., Babin, B. J. & Anderson, R. E. (2010) *Multivariate data analysis* (7th ed.). Upper Saddle River, New Jersey: Pearson Educational International.
- Horwitz, E. K., Horwitz, M. B., & Cope, J. (1986). Foreign language classroom anxiety. *The Modern language journal*, 70(2), 125-132. <https://doi.org/10.2307/327317>

- Hosseini Dowlatabadi, F., Sadeghi, A., Saadat, S., & Khodayari, H. (2014). Relationship between self-efficacy and self-actualization with coping strategies among students. *Research in Medical Education*, 6(1), 10-18. <https://doi.org/10.18869/acadpub.rme.6.1.10>
- Hu L., Bentler P. M. (1999). Cutoff criteria for fit indexes in covariance structure analysis: Conventional criteria versus new alternatives. *Structural Equation Modeling: A Multidisciplinary Journal*, 6, 1-55.
- Hudson, K. (2016). Coping complexity model: Coping stressors, coping influencing factors, and coping responses. *Psychology*, 7(3), 300-309. <https://doi.org/10.4236/psych.2016.73033>
- Kao, P. C., & Craigie, P. (2013). Coping strategies of Taiwanese university students as predictors of English language learning anxiety. *Social Behavior and Personality: an international journal*, 41(3), 411-419. <https://doi.org/10.2224/sbp.2013.41.3.411>
- Kondo, D. S., & Ying-Ling, Y. (2004). Strategies for coping with language anxiety: The case of students of English in Japan. *ELTJournal*, 58(3), 258-265.
- Lazarus, R. S. (1993). Coping theory and research: Past, present, and future. 55,234-247.
- Lazarus, R. S., & Folkman, S. (1984). *Stress, appraisal, and coping*. Springer publishing company.
- Lianto, L. (2019). Self-efficacy: A brief literature review. *Jurnal Manajemen Motivasi*, 15(2), 55-61. <https://doi.org/10.29406/jmm.v15i2.1409>
- MacIntyre, P. D., & Gardner, R. C. (1994). The subtle effects of language anxiety on cognitive processing in the second language. *Language learning*, 44(2), 283-305. <http://dx.doi.org/10.1111/j.1467-1770.1994.tb01103.x>
- Morali, G., & Boran, M. (2021). Exploring the relationship between writing anxiety and writing self-efficacy of international students learning Turkish as a second language. *Cypriot Journal of Educational Science*, 16(4), 2025-2036. <https://doi.org/10.18844/cjes.v16i4.6071>
- Nemati Chalavi, L., Ellahi, M., Pakdel, E., Daneshvar, P., & Yari, K. (2022). The effectiveness of encouragement training in academic anxiety and sense of belonging to school in

- students. *Iranian Evolutionary and Educational Psychology Journal*, 4(3), 584-593. <https://doi.org/10.52547/ieepj.4.3.584>
- Ogrodzinski, Kayle M. (2022). Developing coping strategies for early elementary students in relation to anxiety. *Unpublished MA thesis*. Grand Valley State University, Allendale,
- Özer, Ö., & Akçayoğlu, D. İ. (2021). Examining the roles of self-efficacy beliefs, self-regulated learning and foreign language anxiety in the academic achievement of tertiary EFL learners. *Participatory Educational Research*, 8(2), 357-372. <https://doi.org/10.17275/per.21.43.8.2>
- Pabro-Maquidato, I. M. (2021). The experience of English speaking anxiety and coping strategies: a transcendental phenomenological study. *International Journal of TESOL & Education*, 1(2), 45-64. <https://i-jte.org>
- Piniel, K., & Csizer, K. (2013). L2 motivation, anxiety and self-efficacy: The interrelationship of individual variables in the secondary school context. *Studies in second language learning and teaching*, 3(4), 523-550. <http://www.sllt.amu.edu.pl>
- Rahmat, N. H. (2020). Investigating the cycle of fear in foreign language learning. *European Journal of Foreign Language Teaching*, 5(1), 117-127. <https://doi.org/10.46827/ejfl.v5i1.3245>
- Santri, M., Ikhsanudin, I., & Rezeki, Y. S. (2022). Student's strategies in coping with writing anxiety. *Journey: Journal of English Language and Pedagogy*, 5(2), 160-168. <https://doi.org/10.33503/journey.v5i2.1937>
- Schumacker, R. E., & Lomax, R. G. (2010). *A beginner's guide to structural equation modeling* (3rd ed.). New York, NY: Routledge Academic.
- Scovel, T. (1978). The effect of affect on foreign language learning: a review of the anxiety research. *Language Learning*, 28(1), 129–142. DOI:10.1111/j.14671770.1978.tb00309.x
- Shen, J. (2021). A review of the effectiveness of foreign language enjoyment and foreign language classroom anxiety on learners' engagement and attainment. *Frontiers in Psychology*, 12. <https://doi.org/10.3389/fpsyg.2021.749284>
- Shirazizadeh, M., Fathali, S., & Kamareh, M. (2023). Iranian English Majors' L2 Writing Self-efficacy: Exploring the Effects of Gender, Level of Education, and Teaching Experience. *Iranian Journal of Applied Linguistics*, 26(2), 5-5.

- Speilberger, C. D. (1983). State-trait anxiety inventory for adults (Form Y): sampler set. *Mind Garden*. <https://psycnet.apa.org/doi/10.1037/t06496-000>
- Sun, R. (2022). Influencing factors and coping strategies of English learning anxiety among Chinese non-English major students. *Advances in Social Science, Education and Humanities Research*, 2843-2847. <https://doi.org/10.2991/assehr.k.220504.516>
- Sun, T., & Wang, C. (2020). College students' writing self-efficacy and writing self-regulated learning strategies in learning English as a foreign language. *System*, 90, 102221. <https://doi.org/10.1016/j.system.2020.102221>
- Wang, C., Teng, M. F., & Liu, S. (2023). Psychosocial profiles of university students' emotional adjustment, perceived social support, self-efficacy belief, and foreign language anxiety during COVID-19. *Educational and Developmental Psychologist*, 40(1), 51-62. <https://doi.org/10.1080/20590776.2021.2012085>
- Wheaton, B., Muthen, B., Alwin, D., F., and Summers, G. (1977), "Assessing Reliability and Stability in Panel Models," *Sociological Methodology*, 8 (1), 84-136.
- Yelgeç, N. & Dağyar, M. (2020). A structural equation modelling of middle school students' Metacognitive Awareness, Self-efficacy Beliefs and Foreign Language Learning Anxiety. *International Journal of Contemporary Educational Research*, 7(1), 127-148. <https://doi.org/10.33200/ijcer.657172>
- Yousofi, N., & Ashtarian, S. (2015). Foreign language learning (FLL) anxiety and the coping strategies: The case of Iranian high school students. *International Journal of English and Education*, 4(2), 117-126.
- Zafarani, P., Ahangari, S., & Hadidi Tamjid, N. (2022). Perfectionism, anxiety and English language achievement of Iranian EFL learners: The contribution of performance goal-orientation. *Research in English Language Pedagogy*, 10(3), 389-411. <https://doi.org/10.30486/relp.2021.1940282.1307>
- Zargar, M., & Nimehchisalem, V. (2023). Iranian medical students' EFL writings anxiety, coping strategies, and attitudes towards writing in an online setting. *Open Journal of Modern Linguistics*, 13(1), 26-49. DOI: [10.4236/ojml.2023.131003](https://doi.org/10.4236/ojml.2023.131003).

Zhao, H. (2022). A study on the correlation between psychological anxiety, self-efficacy and foreign language learning achievement. *International Journal of Neuropsychopharmacology*, 25(1), 63-64. <https://doi.org/10.1093/ijnp/pyac032.087>